

±5°-Winkelanwendung **Webcode**
DQDW6M

Planung

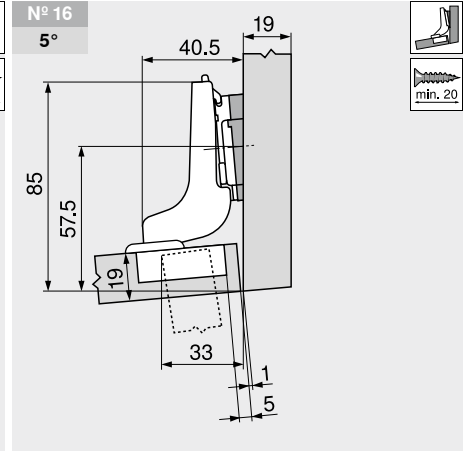
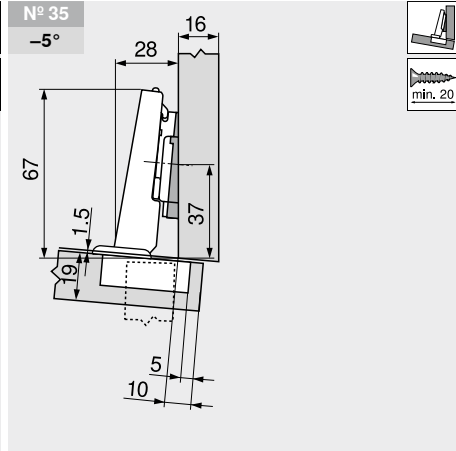
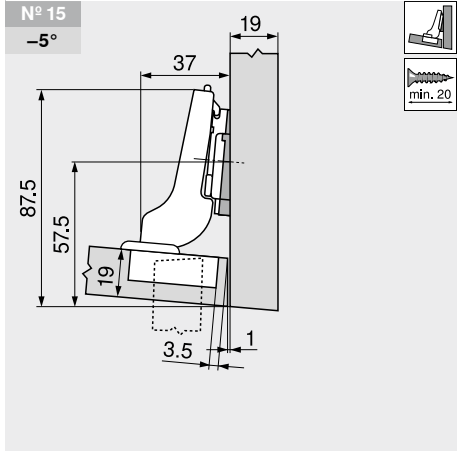

Scharnier mit gekröpftem Scharnierarm

Bezeichnung	Distanz (mm)	Art.-Nr.
Montageplatte	0	173H7100
Winkelkeil	-5°	171A5500

Scharnier mit geradem Scharnierarm

Bezeichnung	Distanz (mm)	Art.-Nr.
Montageplatte	0	173H7100
Winkelkeil	-5°	171A5500

Scharnier mit hochgekröpftem Scharnierarm

Bezeichnung	Distanz (mm)	Art.-Nr.
Montageplatte	0	173H7100
Winkelkeil	+5°	171A5010

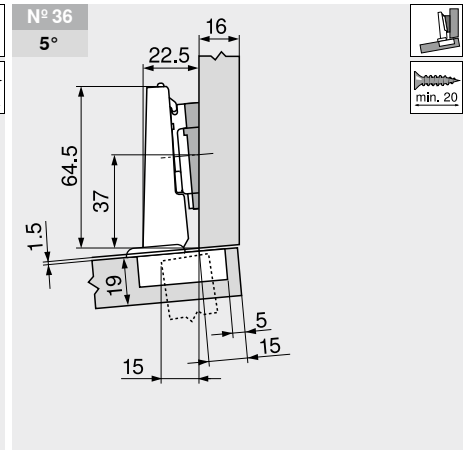
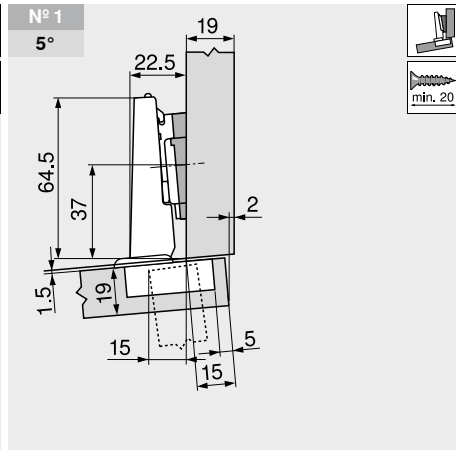
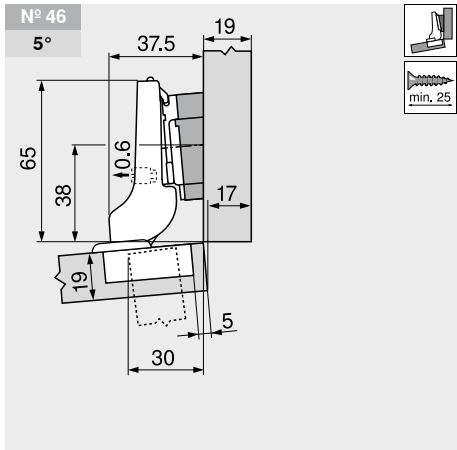

Scharnier mit gekröpftem Scharnierarm

Bezeichnung	Distanz (mm)	Art.-Nr.
Montageplatte	0	173H7100
Winkelkeil	+5°	171A5070

Scharnier mit geradem Scharnierarm

Bezeichnung	Distanz (mm)	Art.-Nr.
Montageplatte	0	173H7100
Winkelkeil	+5°	171A5010

Scharnier mit geradem Scharnierarm

Bezeichnung	Distanz (mm)	Art.-Nr.
Montageplatte	0	173H7100
Winkelkeil	+5°	171A5010

